

FLUIDO®

design by Daniele Del Missier

.1

FLUIDO®

Fluido® means having freedom of expression, being able to choose how to be; being able to change by opting for various possibilities. Suitable for any environment, be it home, office or hospitality, Fluido® fits in with solutions that can be customised at any moment and changed with small, simple gestures. Fluido® is not a collection, it is a new way of conceptualising spaces.

Fluido® significa libertà di espressione, poter scegliere come essere; poter cambiare optando tra le varie possibilità.
Fluido® arreda qualsiasi ambiente sia esso casa, ufficio o hospitality e lo fa con soluzioni personalizzate al momento e che posso variare in qualsiasi istante con piccoli e semplice gesti.
Fluido® non è una collezione, è un nuovo modo di pensare gli spazi.

Fluido® est synonyme de liberté d'expression, de possibilité de choix de la façon d'être, de pouvoir changer en optant pour différentes possibilités.
Fluido® meuble tout environnement, de la maison au bureau en passant par l'hôtellerie, avec des solutions personnalisables sur le moment et transformables en tout temps par de simples petits gestes.
Fluido® n'est pas une collection, mais une nouvelle façon de penser les espaces.

MARTEX



From the ever-changing fish counter comes the idea of Fluido®

Fluido® was born from the idea of the counters at the fish-market in Venice, where every day, depending on the catch, the trays become interchangeable and easily replaceable; all supported by a structure that can be assembled and reused elsewhere. From this vision was born Fluido®, a structure that is easy to assemble and disassemble, which is completed by a series of elements such as tops, trays, drawers, which make the product absolutely customisable according to its function; with the same elements it is possible to create low or high tables, trolleys of various sizes, bookcases and much more.

Dal banco del pesce in continua trasformazione nasce l'idea di Fluido®

Fluido® nasce dall'idea dei banchi del pesce di Venezia, dove ogni giorno a seconda del pescato, le vasche diventano intercambiabili e facilmente sostituibili; il tutto sostenuto da una struttura assemblabile, e riutilizzabile in altro sito.

Da questa visione nasce Fluido®, una struttura facile da montare e smontare, che viene completata con una serie di elementi quali piani, vasche, cassetti, che rendono il prodotto assolutamente personalizzabile in base alla funzione; con gli stessi elementi si possono creare tavoli bassi, alti, carrelli di varie dimensioni, librerie e molto altro.

C'est du comptoir à poissons en transformation rapide qu'est née l'idée de Fluido®.

Fluido® est né de l'idée des comptoirs de vente de poissons de Venise, où chaque jour, en fonction de la pêche, les bacs deviennent interchangeables et facilement remplaçables; le tout soutenu par une structure qui peut être assemblée et réutilisée ailleurs. De cette vision naît Fluido®, une structure facile à assembler et désinstaller, complétée par une série d'éléments tels que des plateaux, des bacs, des tiroirs, qui rendent le produit absolument customisable selon sa fonction; avec les mêmes éléments, il est possible de créer des tables basses et hautes, des chariots de différentes tailles, des bibliothèques et bien plus encore.

FLUIDO ♥ THE PLANET

Martex is determined to act in response to the ecological and social impact on our planet by making conscious choices about what we produce. Understanding the consequences of one's decisions is a big step towards responsible production and consumption. Our goal is to make sustainable products from their inception from scratch on paper and then to continuously improve their design according to eco-social criteria. Sustainable products last without endangering the future of generations to come.

Martex è determinata ad agire in risposta alla crisi ecologica e sociale che colpisce il nostro pianeta, facendo scelte consapevoli su ciò che produciamo. Comprendere l'impatto delle proprie decisioni è un grande passo avanti verso una produzione e di conseguenza un consumo responsabile. Il nostro obiettivo è realizzare prodotti sostenibili fin dalla loro nascita su carta e poi migliorando continuamente la loro progettazione secondo criteri eco-socio-sostenibili. I prodotti sostenibili durano nel tempo senza mettere a repentaglio il futuro delle generazioni a venire.

Martex est déterminée à répondre à la crise écologique et sociale qui affecte notre planète en faisant des choix conscients sur notre production. Comprendre l'impact des décisions est un grand pas vers une production et par conséquent une utilisation responsable. Notre objectif est de concevoir des produits durables dès leur conception initiale et de les améliorer constamment sur la base de critères éco-socio-écologiques. Les produits durables résistent dans le temps sans compromettre le futur des générations à venir.

- Product that can be transformed and is infinitely reusable for a circular economy
Prodotto che può trasformarsi ed è riutilizzabile all'infinito per un'economia circolare
Produit transformable et réutilisable à l'infini pour une économie circulaire
- No screws, assembly in just a few steps, no tools required
Nessuna vite, assemblaggio in pochi gesti, non servono utensili
Absence de vis, montage en peu de gestes, pas d'outils nécessaires.
- 100% recyclable
100% riciclabile
100% recyclable
- Certified and recyclable packaging with low-volume, easy to transport
Imballo certificato e riciclabile con volume ridotto, facilmente trasportabile
Emballage certifié et recyclable à faible volume, facilement transportable
- Available in environmentally sustainable and certified materials, such as 100% recycled paper
Disponibile in materiali ecosostenibili e certificati, come la carta riciclata al 100%
Disponibile en matériaux écologiques et certifiés, comme le papier 100% recyclé
- CARB2 certified tops
Piani certificati CARB2
Plateaux certifiés CARB2
- Easily and completely disassembled
Facilmente e completamente disassemblabile
Facilement et complètement démontable
- Patent of ingeniousness
Brevetto d'ingegno
Ingéniosité du brevet
- Objective 12 responsible consumption and production SDG (Sustainable Development goals)
Obiettivo 12 consumo e produzioni responsabili SDG (Sustainable Development goals)
Objectif 12 consommation et production responsables ODD (Objectifs de Développement Durable)



“Caddy Fluido®” reconfigurability and customisation at your fingertips

Today, a room can be transformed in the course of the same day into a different environment: from a meeting room, to a training room, to individual work.

For this reason, space requires the ability to change flexibly and dynamically. In this perspective of effectiveness and versatility, the undisputed protagonists are the furnishings. Flexible furniture, which allows you to change from one configuration to another depending on the purpose, adapting in a practical and fast way to all requirements. Furniture that have to be reconfigured by the user easily and intuitively, without requiring the intervention of specialised personnel.

Oggi una stanza può trasformarsi, nell'arco della stessa giornata, in un ambiente diverso: da sala riunione, a sala training, a lavoro individuale. Per questo motivo lo spazio deve poter mutare in modo flessibile e dinamico. In quest'ottica di efficacia e versatilità i protagonisti indiscussi sono gli arredi. Arredi flessibili, che permettono di passare da una configurazione ad un'altra a seconda della destinazione, adattandosi in modo pratico e veloce a tutte le esigenze. Arredi che devono essere riconfigurati dall'utente in maniera agevole e intuitiva, senza richiedere l'intervento di personale specializzato.

Aujourd'hui, une pièce peut se transformer au cours d'une même journée en milieux différents: de salle de réunion, à salle de formation, à poste de travail individuel. C'est pourquoi l'espace doit pouvoir se transformer de manière flexible et dynamique. Dans cette perspective d'efficacité et de versatilité, les protagonistes incontestés sont les mobiliers flexibles, qui permettent de passer d'une configuration à une autre selon la destination, s'adaptant à toutes les exigences de manière simple et rapide. Mobiliers qui doivent être réaménagés par l'utilisateur de façon simple et intuitive, sans nécessiter d'intervention de personnel spécialisé.





One shot assembly! without screws and tools

Thanks to an ingenious patent, the product can be assembled with bare hands, without any screws or tools of any kind. Small and very fast movements to create your own workstation. This means not only time savings, but also a lower environmental impact since no screws are included in the packaging. The table can be customised by choosing the configuration that best suits the function at the time. Assembly takes place in just a few steps by any user, as the elements that make up Fluido® are light and easy to move.

Grazie ad un brevetto d'ingegno, il prodotto si monta a mani nude, senza nessuna vite e senza bisogno di utensili di alcun tipo. Piccoli e velocissimi movimenti per creare la propria postazione. Questo vuol dire non solo risparmio di tempo, ma anche un minor impatto ambientale dato che negli imballi non è prevista alcuna viteria. Il tavolo si può personalizzare scegliendo la configurazione che in quel momento più si addice alla funzione che si deve svolgere. Il montaggio avviene in pochissimi passaggi effettuati da qualsiasi utente, in quanto gli elementi che compongono Fluido® sono leggeri e facilmente movimentabili.

Grâce à un brevet ingénieux, le produit peut être assemblé à mains nues, sans vis ni outils d'aucune sorte. De petits gestes très rapides pour créer son propre poste de travail. Cela signifie non seulement un gain de temps, mais aussi un impact environnemental réduit car aucune visserie ne figure dans l'emballage. La table peut être personnalisée en choisissant la configuration qui convient le mieux à la fonction du moment. Le montage se fait en peu de gestes par tous les utilisateurs, car les éléments qui composent Fluido® sont légers et faciles à manipuler.



Light, strong and human scaled

Once the components necessary to assemble the structure have been taken from the trolley, without the aid of any tools and with simple movements, it is now possible to equip the table with tops in different materials by choosing from the wide range of options Martex offers: melamine, laminate, Paperstone®, lacquer or wood veneer. It is now possible to add or prepare the accessories required to customise the table for the specific function it is intended to perform: personal storage drawer, front screen, bag hook, kit for attaching other tables.

Una volta presi dal carrello i componenti necessari al montaggio della struttura, senza l'ausilio di nessun strumento e con semplici movimenti, è possibile ora attrezzare il tavolo con piani in diversi materiali, scegliendo dall'ampia gamma di opzioni che Martex offre: melaminico, laminati, Paperstone®, laccati o impiallacciati in legno. Si può ora aggiungere o predisporre gli accessori necessari alla personalizzazione del tavolo per la specifica funzione a cui deve provvedere: cassetto portaoggetti personali, screen frontale, gancio porta borsa, kit di aggancio altri tavoli.

Une fois prélevés du chariot les éléments nécessaires au montage de la structure, sans l'aide d'outils et par de simples gestes, il est possible d'équiper la table avec des plateaux en différents matériaux, à choisir parmi la vaste gamme d'options proposées par Martex: mélamine, stratifié, Paperstone®, laqué ou placage bois. Dès ce moment, il est possible d'ajouter ou de prévoir les accessoires nécessaires à la personnalisation de la table conformément à la fonction spécifique recherchée: tiroir de rangement personnel, écran frontal, porte-sac, kit d'accrochage aux autres tables.







Tables can be joined together laterally thanks to connections available in the same finish as the top and can be customised with trays and electrical equipment.
On request, a round profile made of soft, conformable material can be easily inserted along the upper perimeter slot of the table.

I tavoli posso essere uniti lateralmente tra loro grazie a delle connessioni disponibili nella stessa finitura del piano e personalizzabili con vasche ed elettrificazione.
A richiesta, un profilo cilindrico in materiale morbido e conformabile, può essere inserito con facilità lungo la cava superiore perimetrale del tavolo.

Les tables peuvent être reliées latéralement par des connexions disponibles en teinte avec le plateau et personnalisables avec bacs et électrification.
L'écran peut être repositionné en le glissant sur le périmètre.
Sur demande, un profil arrondi en matériau souple et conformable peut être facilement introduit le long de la rainure du périmètre supérieur de la table.

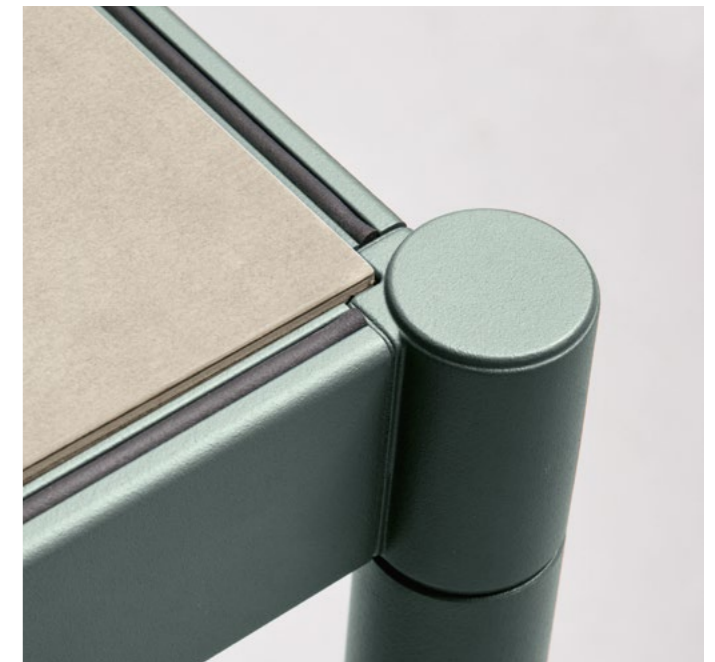
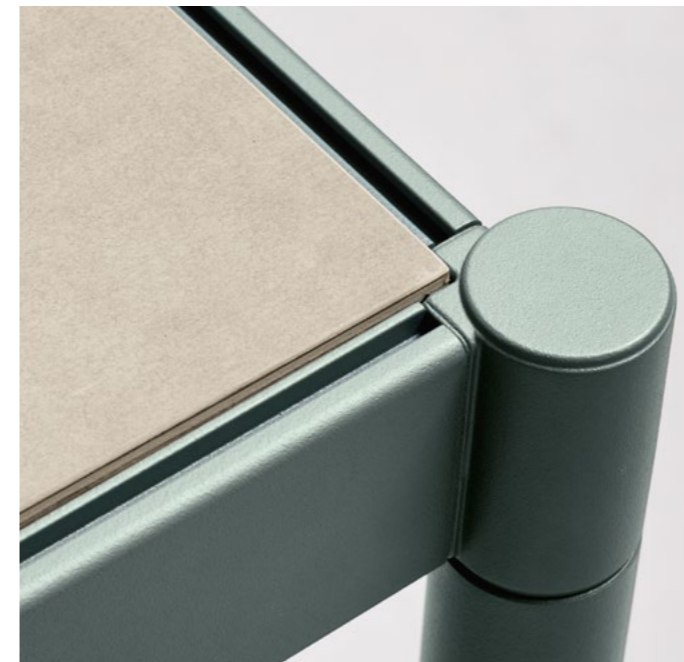

Tables like the fish stands can be customised according to the needs of the day. Storage drawers, bag trays and electrified compartments are some of the elements that characterise the collection.

I tavoli come i banchi del pesce possono essere personalizzati in base alle esigenze della giornata. Cassettini portaoggetti, vasche portaborsa e vani elettrificati sono alcuni degli elementi che caratterizzano la collezione.

Les tables, comme les comptoirs de vente de poissons, sont configurables pour répondre aux exigences de la journée. Tiroirs vide poches, porte-sacs et compartiments électrifiés sont quelques éléments qui caractérisent la collection.



Thanks to the grooves in the perimeter beams, the screen can be quickly and easily attached and detached without the use of hardware.

Grazie alle cave presenti nella sezione delle travi perimetrali, lo screen si aggancia e sgancia in maniera facile e veloce, senza l'utilizzo di ferramenta.

Grâce aux rainures dans les profils du périmètre, l'écran peut être attaché et détaché de manière rapide et facile, sans utiliser aucune visserie.

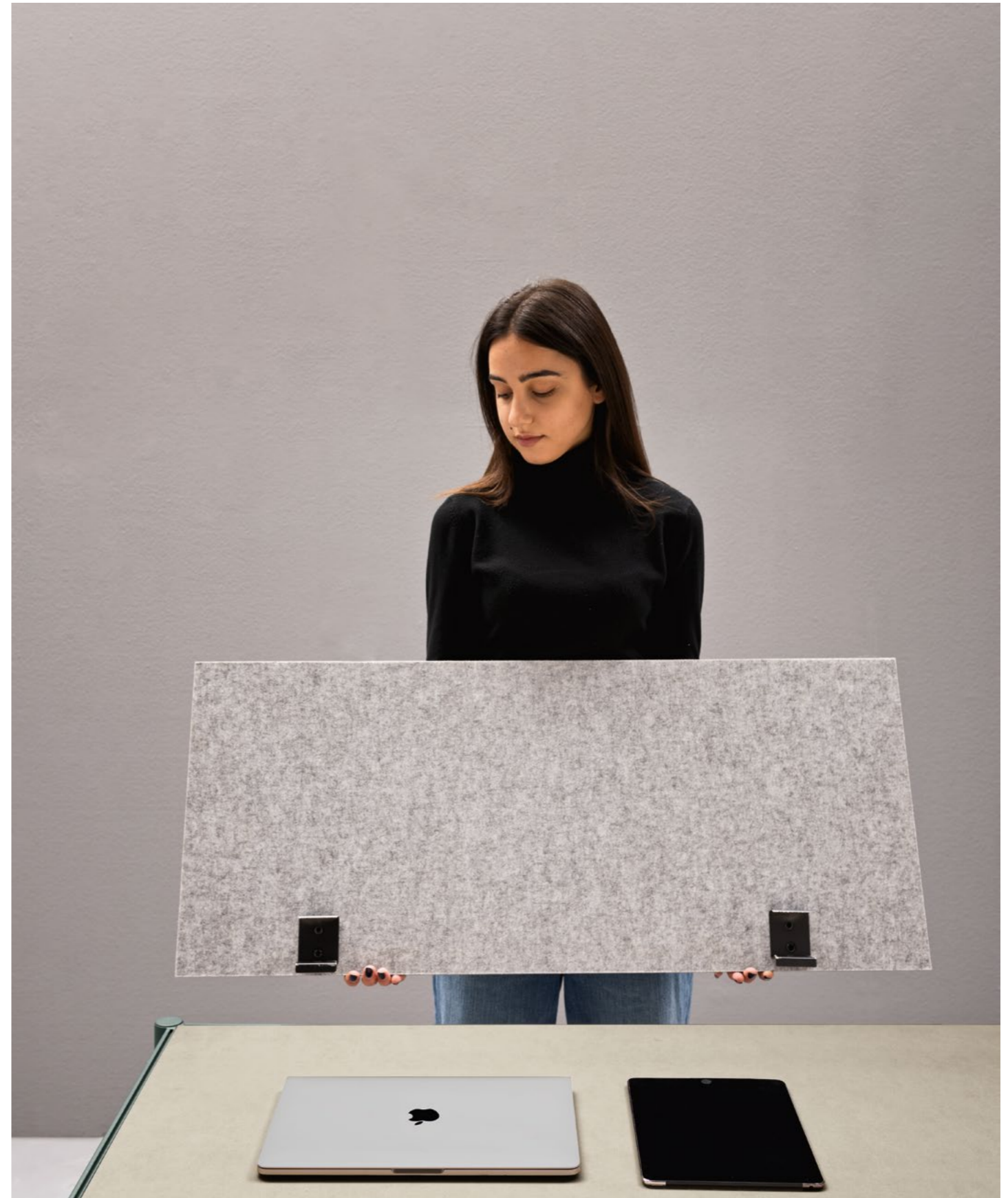





High table W. 2400 D. 800 mm, tops in Super Matt finish with concealed USB sockets. The bag hooks can be positioned and relocated anywhere on the frame.

Tavolo alto L. 2400 P. 800 mm, piani in finitura Super Matt con prese usb incassate. I ganci portaborse possono essere posizionati e ricollocati in qualsiasi punto del telaio.

Table haute L. 2400 P. 800 mm, plateaux en finition Super Matt avec prises USB intégrées. Les supports porte-sac peuvent être positionnés et déplacés librement sur le châssis.



In addition to its storage or support function, the trolley can become a real working tool; the pinnable felt back not only separates but can also be used to pin down ideas and share them. The backs of the trolleys are easily positioned thanks to a practical button fastening; this allows the element to be configured as required, transforming from a single-sided to a double-sided container with a simple gesture.

Oltre alla funzione di contenimento o appoggio il carrello può diventare un vero e proprio strumento di lavoro; la schiena in feltro pinnabile non solo separa ma può essere utilizzata per appuntare idee e condividerle.

Le schiene dei carrelli sono facilmente posizionabili grazie ad un pratico aggancio con bottone; questo permette di configurare l'elemento a seconda delle necessità, trasformandosi, con un semplice gesto, da contenitore monofacciale a bifacciale.

En plus de sa fonction de stockage ou de support, le chariot peut devenir un véritable outil de travail; le dossier en feutre punaisable permet non seulement de séparer mais aussi de fixer des idées et de les partager. Les dos des chariots se positionnent facilement grâce à un pratique système de connexion par boutons; cela permet de configurer l'élément selon les besoins, en passant d'une version simple à double face d'un simple geste.







Not only simple trolleys but also complete storage solutions, with fridge, doors and drawers and integrated electrification, all available on wheels or feet.

Non solo semplici carrelli ma anche complete soluzioni di contenimento, con frigo, ante e cassetti ed elettrificazione integrata, il tutto disponibile sia su ruote che su piedini.

Non seulement simple chariot mais aussi solutions de stockage complètes, avec réfrigérateur, portes et tiroirs et électrification intégrée, le tout disponible sur roulettes ou sur patins.



SPECS SHEETS

Caddy Fluido

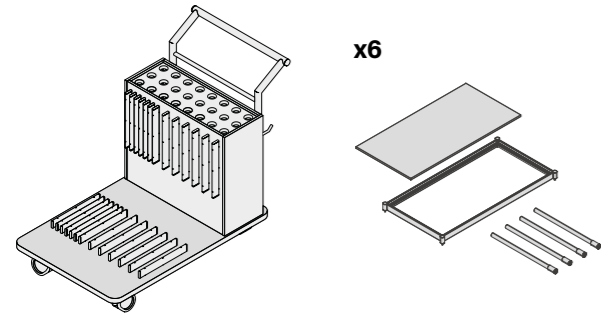

x6

Table accessories | Accessori Tavoli | Accessoires de table

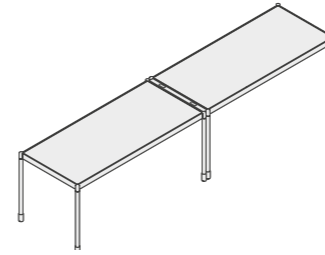

Connection element with or without cable management
Elemento di connessione con o senza elettrificazione
Élément de connexion avec ou sans électrification

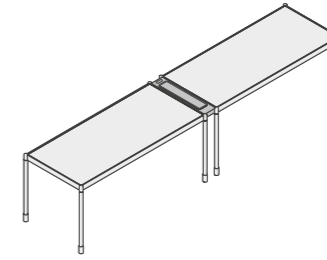

Connection tray
Vasca di connessione
Bac de connexion

Tables | Tavoli | Tableaux

* always available in version with feet or wheels / sempre disponibili sia nella versione su piedi che su ruote / toujours disponible en la version sur patins et sur roulettes

H. 750 mm

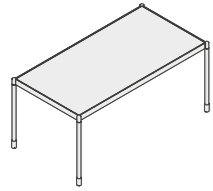

Table on feet
Tavolo su piedi
Table sur patins

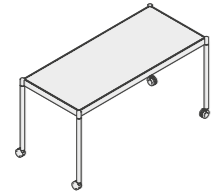
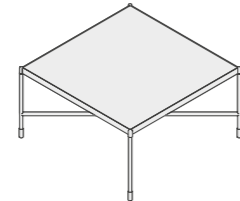
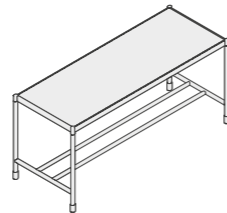

Table on wheels
Tavolo su ruote
Table sur roulettes



H. 950 mm



Trolleys | Carrelli | Chariot à roulettes

H. 1000 mm

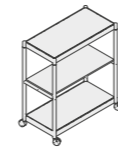

H. 1430 mm

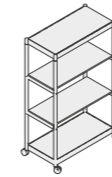

H. 1870 mm

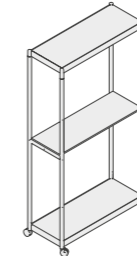

H. 1870 mm

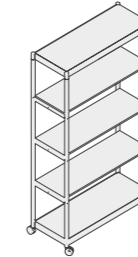
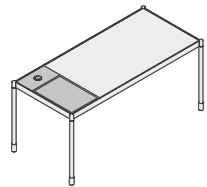
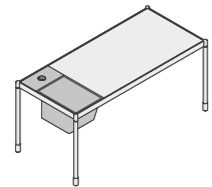

Table accessories | Accessori Tavoli | Accessoires de table



Storage drawer
Cassetino
Tiroir vide poches



Bag tray
Cassetto porta borse
Tiroir porte sacs

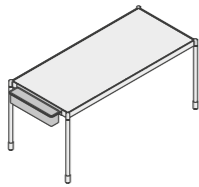

Lateral tray
Vasca laterale
Bac latéral

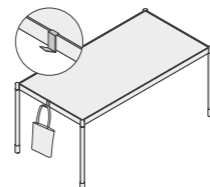

Bag holder
Gancio portaborse
Crochet pour sacs

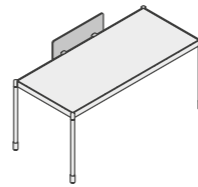

Screen
Screen
Cloisonette

Modulo bar | Bar counter | Meuble bar

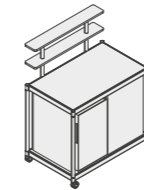
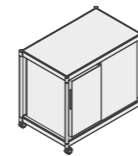

Kitchenette

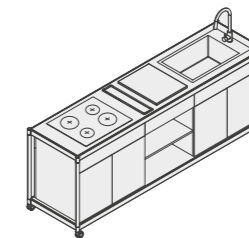

Standard Colours & Finishes

Colours for reference only and may vary from original. Fabrics and leathers from different lots may be subject to colour variations. Any differences will not be recognized as a complaint.

Campioni colore indicativi, possono differire dall'originale. Tessuti e pelli possono essere soggetti a cambiamenti e a differenze tra lotti diversi. Eventuali differenze non verranno riconosciute come reclamo.

Les couleurs sont données à titre indicatif et peuvent varier par rapport à l'original. Les tissus et les cuirs provenant de lots différents peuvent être sujets à des variations de couleur. Les différences éventuelles ne seront pas considérées comme une réclamation.

ALUMINUM

ALLUMINIO | ALUMINIUM



051 Nero

070 Verde Giada

WOOD

LEGNO | BOIS

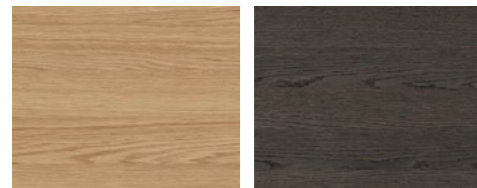

RCL 004 Rovere Classico

RTA 005 Rovere Tabacco

MEL

MELAMINE | MELAMINICI | MÉLAMINE



038 Bianco

068 Grigio Nuvola

079 Rovere Sabbia

034 Rovere Naturale

057 Nocciolo

FX

FENIX® | FENIX®



059 Grigio Efeso

060 Beige Arizona

061 Grigio Bromo

063 Verde Comodoro

055 Black

LAC

MATT LACQUERED | LACCATO OPACO | LAQUÉ MAT



401 Bianco

430 Pioggia

427 Corda

403 Crema

428 Cappuccino

434 Cipria



435 Rosa Antico

438 Verde Salvia

439 Verde Giada

436 Verde Bosco

432 Avio

437 Blu Notte



421 Ocra

417 Titanio

418 Fondente

429 Ombra

419 Grigio Carbone

420 Nero

SCREEN AND TROLLEY BACK PANELS | SCREEN E SCHIENE PER TROLLEY | ECRANS ET DOS POUR TROLLEY

polySONIC®



100 Grigio

100% PES

ACUSTIC

5 mm (0,20"): aw = 0,15 | NRC = 0,15

10 mm (0,40"): aw = 0,25 | NRC = 0,35

© Copyright 2023 Martex S.p.A. Prata di Pordenone (PN) - Italy. All rights reserved. Confidential material of relevant economic value, property of Martex S.p.A. Reproduction and/or disclosure, even partial, to third parties is prohibited without specific written authorisation from Martex management. Martex reserves the rights at all time to apply modifications for the functional or qualitative improvement of its products. Texts and drawings present in this brochure have a divulgative purpose: for every technical and dimensional aspect please refer to the company's price lists and their relative updatings. The colour and material samples have an indicative value.

© Copyright 2023 Martex S.p.A. Prata di Pordenone (PN) - Italia. Tutti i diritti riservati. Materiale riservato di rilevante valore economico, di proprietà della Martex S.p.A. Vietata la riproduzione e/o divulgazione anche parziale a terzi senza autorizzazione scritta specifica della direzione Martex. Martex si riserva il diritto di apportare, senza preavviso, ogni modifica mirata al miglioramento funzionale e qualitativo dei propri prodotti. Testi e disegni presenti in questo stampato hanno scopo divulgativo: per ogni aspetto tecnico e dimensionale fare riferimento ai listini aziendali e relativi aggiornamenti. I campioni di colori e materiali hanno valore indicativo.

© Copyright 2023 Martex S.p.A. Prata di Pordenone (PN) - Italie. Tous les droits sont réservés. Matériel confidentiel de valeur économique considérable, propriété de Martex S.p.A. Ne pas reproduire et/ou divulguer, même partiellement, à des tiers sans autorisation écrite spécifique de la direction de Martex. Martex se réserve à tout moment le droit d'appliquer des modifications pour l'amélioration fonctionnelle ou qualitative de ses produits. Les textes et les dessins présents dans cette brochure ont un but informatif: pour chaque aspect technique et dimensionnel, veuillez-vous référer aux tarifs de la société et à leurs mises à jour. Les échantillons de couleurs et de matériaux ont une valeur indicative.

CREDITS

Graphics: MKT Martex
Photo: Gabriotti Fotografi
Print: Grafiche Antiga
Photolitho: Lucegroup

April 2023

Martex S.p.A.
via Sagré, 19 - 33080
Prata di Pordenone (PN) Italy
tel +39 0434 602310
fax +39 0434 602319

info@martex.it
www.martex.it